

# WELL HEAD CLEANING TOOL

The **Well Head Cleaning Tool** is a hydraulically powered hub cleaning tool designed for safe and reliable deployment and operation by an ROV. Replaceable 3m Scotch-Brite brushes are secured to a cleaning head driven by a hydraulic motor.

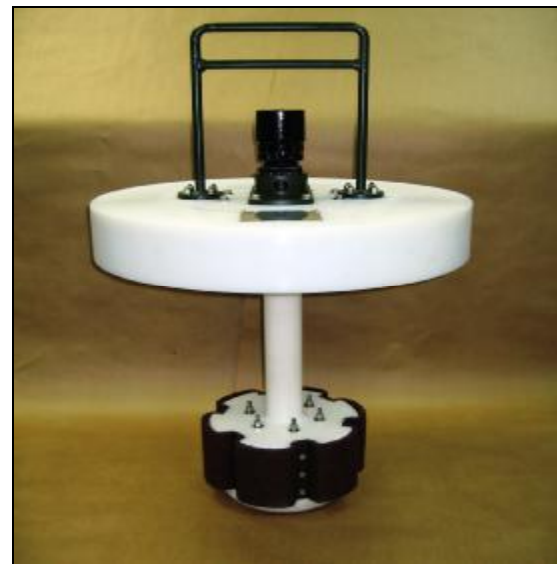
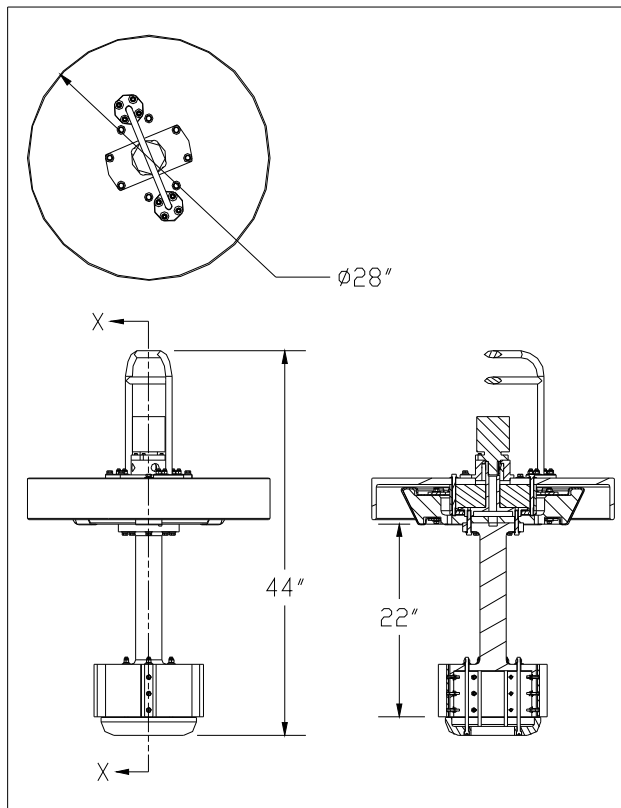

## SPECIFICATIONS

### WELLHEAD CLEANING TOOL

|                             |  |
|-----------------------------|--|
| <b>Material:</b>            | UHMD Plastic<br>& Xylan coated-Carbon<br>Steel |
| <b>Overall Dimensions:</b>  | 28" Dia X 44" Tall                             |
| <b>Weight in Air:</b>       | 130 Lbs  |
| <b>Hydraulic Motor:</b>     | Parker TE0045                                  |
| <b>Flow Rate Required:</b>  | 10 GPM   |
| <b>Max Supply Pressure:</b> | 2900 PSI                                       |
| <b>Gasket Seal Surface:</b> | 18.75" Nominal Diameter                        |
| <b>Bore Seal Surface:</b>   | 13" Nominal Diameter                           |
| <b>Connections:</b>         | 3/8" JIC                                       |